



SUPER-G[®] MODULES

Ultrafiltration Multitube Modules for Juice Processing

PRODUCT DESCRIPTION

Membrane Material: PVDF
Membrane Type: HFM-500 or HFM-513
Molecular Weight Cutoff*: HFM-500: 100,000 Daltons
 HFM-513: 500,000 Daltons
Configuration: Four (4) 1" diameter tubules in polysulfone shell
Applications: Juice processing for high recovery and high solids
Regulatory Information: Conforms with FDA regulations (CFR Title 21)
Options: HFM-500 membrane for light juices
 HFM-513 for all juices

* - The nominal separation range and retention characteristics of the membranes are highly dependent upon the nature of the liquid being processed and on several other operating parameters. This information should, therefore, be used as a guide only

SPECIFICATIONS

Part Numbers	Model	Membrane Area ft ² (m ²)
0712001	SUPER-G [®] 3010-HFM-500	9.3 (0.9)
0712071	SUPER-G [®] 3010-HFM-513	9.3 (0.9)

OPERATING AND DESIGN INFORMATION*

Maximum Operating Pressure: 90 psi @ 120°F (6.2 bar @ 49°C)
Minimum Outlet Pressure: 10 psi (0.7 bar)
Maximum Permeate Pressure: 5 psi (0.3 bar)
Typical Feed Side Pressure Drop Per Module: 4-6 psi (0.27-0.40 bar)
Maximum Feed Side Pressure Drop Per Module: 6.6 psi @ 130°F (0.5 bar @ 54°C)
Maximum Operating Temperature at pH 8: 130°F (54°C)
Allowable pH Range at 120°F (49°C): Continuous 2.0 – 10.0
 Short term 1.5 – 10.5
Maximum Chlorine (cleaning): 200 ppm @ pH 10-10.5, 120°F (49°C)

* Consult KMS Process Technology Group for specific applications.

NOMINAL DIMENSIONS

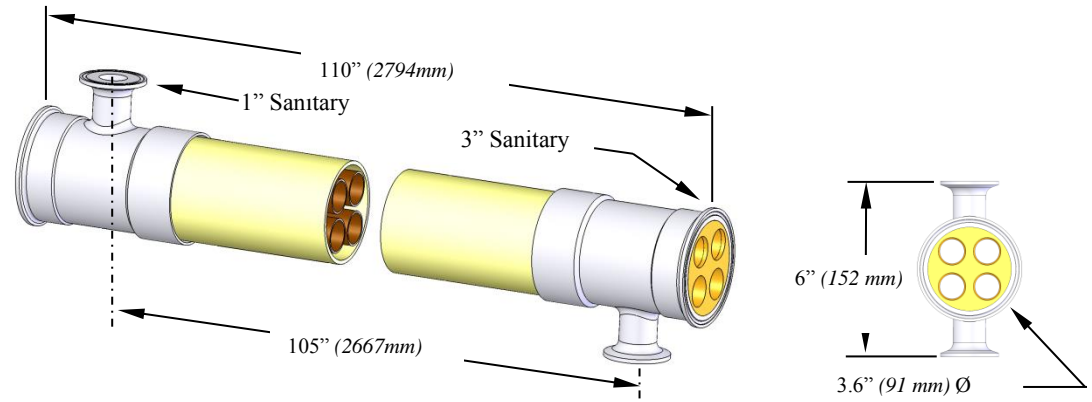

SUPER-G® TUBULAR MODULE ASSEMBLY

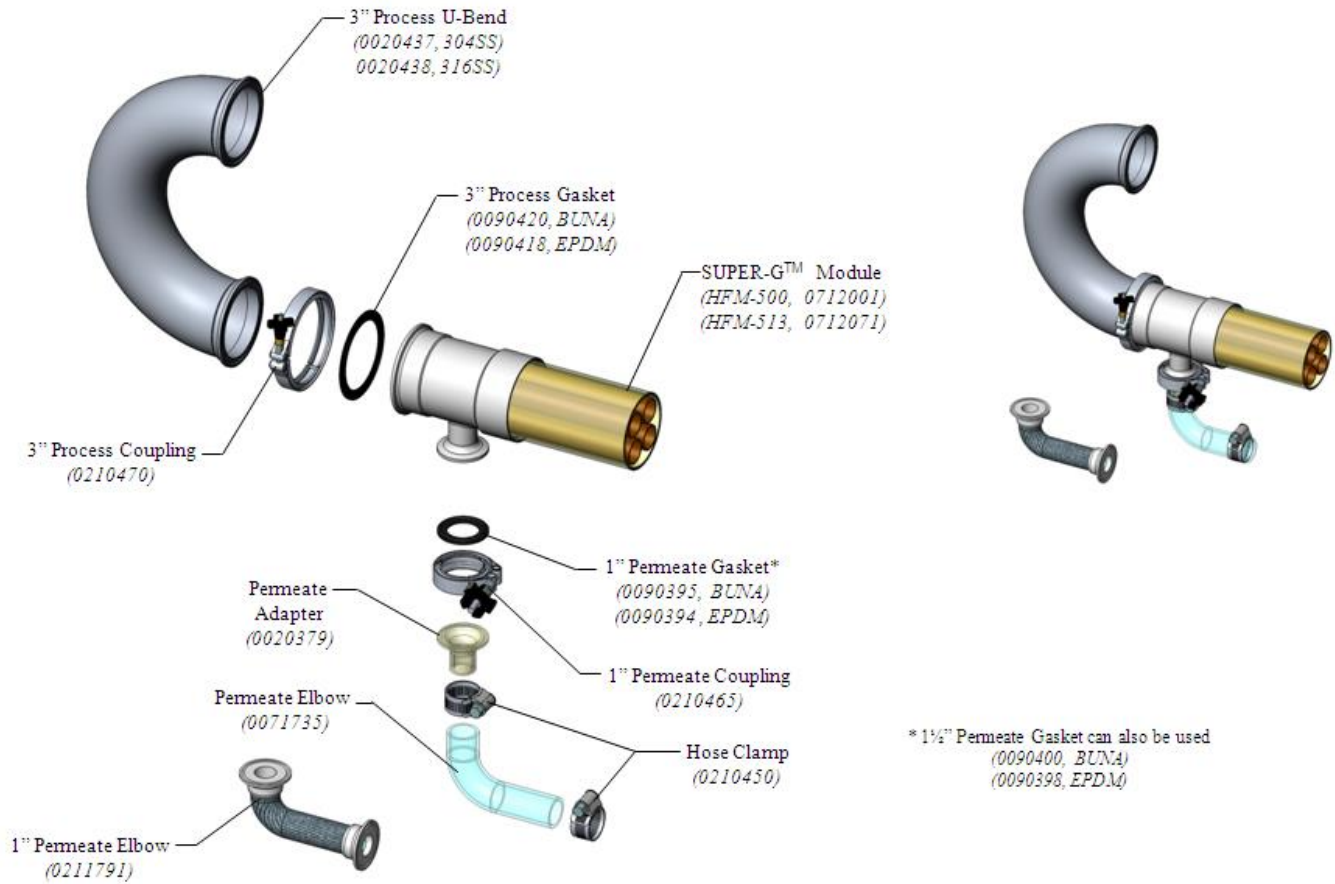

Service and Ongoing Technical Support:

Koch Membrane Systems (KMS) has an experienced staff of professionals available to assist end-users and OEM's for optimization of existing systems and support with the development of new applications. Along with the availability of supplemental technical bulletins, KMS also offers a complete line of KOCHKLEEN® membrane pretreatment, cleaning and maintenance chemicals.

KMS Capability

KMS is the leader in crossflow membrane technology, manufacturing reverse osmosis, nanofiltration, microfiltration, and ultrafiltration membranes and membrane systems. The industries we serve include food, dairy, beverage, automotive, water and wastewater, chemical, and general manufacturing. KMS adds value by providing top quality membrane products and by sharing our experience in the design and supply of thousands of crossflow membrane systems worldwide.

The information contained in this publication is believed to be accurate and reliable, but is not to be construed as implying any warranty or guarantee of performance. We assume no responsibility, obligation, or liability for results obtained or damages incurred through the application of the information contained herein. Refer to Standard Terms and Conditions of Sale and Performance Warranty documentation for additional information.

Koch Membrane Systems, Inc., www.kochmembrane.com

Corporate Headquarters: 850 Main Street, Wilmington, Massachusetts 01887-3388, US, Tel. Toll Free: 1-888-677-5624, Telephone: 1-978-694-7000, Fax: 1-978-657-5208
European Headquarters: Koch Chemical Technology Group Ltd., Units 3-6, Frank Foley Way, Stafford ST16 2ST, GB, Telephone: +44-178-527-2500, Fax: +44-178-522-3149

• Aachen DE • Lyon FR • Madrid ES • Milan IT • Wijnegem BE • Beijing & Shanghai CN • Mumbai & New Delhi IN • Melbourne & Sydney AU • Singapore • Sao Paulo BR • Dubai UAE •

For related patent and trademark information, visit www.kochmembrane.com/legal
Koch Membrane Systems, Inc. is a Koch Chemical Technology Group, LLC company.
© 2015 Koch Membrane Systems, Inc. All rights reserved worldwide.