



ROMICON® 6" HOLLOW FIBER CARTRIDGES

6" Diameter Hollow Fiber Ultrafiltration Cartridges

PRODUCT DESCRIPTION

Membrane Polymer: Polysulfone
Housing Construction: Polysulfone
Seal/Potting Material: Proprietary Epoxy Compound
Storage Solution: Glycerin
Regulatory Status: Selected PM5, PM10, PM50 and PM500 cartridges are compliant with US FDA CFR Title 21 and EC Reg. Nos. 1935/2004, and 10/2011.

Options:

Lumen size: 20 mil (0.5 mm), 43 mil (1.1 mm), 60 mil (1.5 mm), 75 mil (1.9 mm), 106 mil (2.7 mm)
Membrane Type: PM5, PM10, PM30, PM50, PM100, or PM500

Special Construction for Specific Applications:

Vinegar Filtration: Selected PM50 and PM500 cartridges are available for vinegar filtration.
Citrus Filtration: Selected PM10, PM50 and PM500 cartridges are available for citrus filtration.
ROMIPRO™ Cartridges: Selected cartridges of all membrane types are available with components that have passed USP Class VI test guidelines.

CARTRIDGE AVAILABILITY AND MEMBRANE AREA

Membrane Type	MWCO (Dalton)	Fiber Diameter [mil (mm)]			
		43 (1.1)	60 (1.5)	75 (1.9)	106 (2.7)
PM5	5,000	•			
PM10	10,000	•	•		
PM30	30,000	•			
PM50	50,000	•	•	•	
PM100	100,000	•			
PM500	500,000	•		•	•
Membrane Area [ft² (m²)]		97 (9.0)	97 (9.0)	80 (7.4)	64 (5.9)

OPERATING AND DESIGN INFORMATION*

Maximum Inlet Pressure: 40 psi (2.8 bar)
Maximum Transmembrane Pressure: 35 psi (2.4 bar)
Maximum Operating Temperature (at pH 6.0): 140°F (60°C)
Maximum Cleaning Temperature: 130°F (54°C)
Maximum Permeate Side Back Pressure: 20 psi (1.4 bar)
Maximum Differential Pressure Feed Side: 30 psi (2.1 bar)
Allowable pH: 1.5 – 13.0 @ 130°F (54°C)
Maximum Total Chlorine (During Cleaning): 200 ppm @ pH 10-10.5, 130°F (54°C)
 0 ppm @ pH less than 9.5

* Consult KMS Process Technology Group for specific applications.

NOMINAL DIMENSIONS

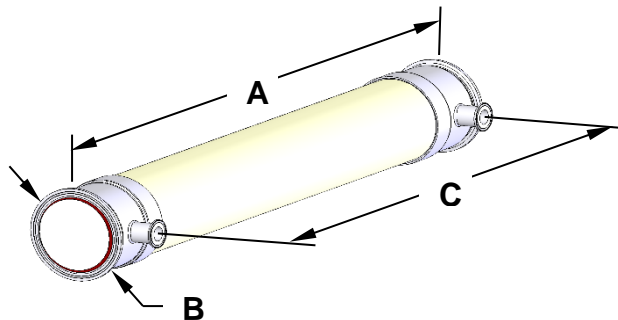

A	B	C	Permeate Connection	Process Connection
inches (mm)	inches (mm)	inches (mm)		
43 (1,092)	6.67 (169.4)	38 11/16 (982.7)	1/2" sanitary	6" sanitary

ROMICON® 6” HOLLOW FIBER CARTRIDGES

MEMBRANE CHARACTERISTICS

ROMICON® cartridges should be selected for filtration of liquids based on the separation range needed. They provide stable productivity, ease of cleaning and reliable operation. KMS ROMICON® cartridges are crossflow-type filters, in which the feed solution is pumped across the cartridge to minimize solids cake buildup on the membrane. Crossflow filters provide efficient filtration at low operating pressure, allowing long process runs while reducing cleaning time, cleaning frequency, and labor costs.

6” HOLLOW FIBER CARTRIDGE HARDWARE

Item	Part Description	KPN
1	6” gasket	0090424
2	6” Process Cap adapter	0040321
3	6” Coupling	1020262
4	2½” Cartridge Gasket	EPDM 0090411 BUNA 0090410
5	2½” Coupling	0210468
6	1” Gasket	EPDM 0090394 BUNA 0090395
7	1” Coupling	0210465

6” pass kit containing the above parts (EPDM seals) 1007055

LUBRICANTS

For cartridge installation, use only water or glycerin to lubricate seals. The use of petroleum or vegetable-based oils or solvents may damage the cartridge and will void the warranty.

EXPOSURE TO CHEMICAL OXIDANTS

Exposure to chemical oxidants for thorough cleaning and sanitization may prove necessary and useful.

- Chemical oxidants commonly used in food applications include peracetic acid blends, hydrogen peroxide, and sodium hypochlorite. Please consult KMS for recommended addition rates, frequency of use, and tolerance.
- Potassium metabisulfite (without catalyst such as cobalt) is the preferred chemical to eliminate residual chlorine or similar oxidizers prior to processing the feed stream.

KMS CAPABILITY

KMS is the leader in crossflow membrane technology, manufacturing reverse osmosis, nanofiltration, microfiltration, and ultrafiltration membranes and membrane systems. The industries served include food, dairy and beverage, pharmaceutical, biotechnology, water and wastewater, semiconductors, automotive, chemical and general manufacturing. KMS adds value by providing top quality membrane products and by sharing its experience in the design and supply of thousands of crossflow membrane systems worldwide.

SERVICE AND ONGOING TECHNICAL SUPPORT

Koch Membrane Systems, Inc. has an experienced staff of professionals available to assist end-users and OEMs for optimization of existing systems and support the development of new applications. Along with the availability of supplemental technical bulletins, Koch Membrane Systems, Inc. also offers a complete line of KOCHKLEEN® cleaning chemicals.



The information contained in this publication is believed to be accurate and reliable, but is not to be construed as implying any warranty or guarantee of performance. We assume no responsibility, obligation or liability for results obtained or damages incurred through the application of the information contained herein. Refer to Standard Terms and Conditions of Sale and Performance Warranty documentation for additional information.

Koch Membrane Systems, Inc., www.kochmembrane.com

Corporate Headquarters: 850 Main Street, Wilmington, Massachusetts 01887-3388 USA. Tel.: 1-888-677-KOCH.

For related trademark information, visit www.kochmembrane.com/legal

Koch Membrane Systems, Inc. is a Koch Chemical Technology Group, LLC company.

© 2016 Koch Membrane Systems, Inc. All rights reserved worldwide.

Rev 16-1